

Distributed Multi-channel Controller DMC10E User's Manual



Thank you for purchasing the Distributed Multi-channel Controller DMC10E.

This manual describes only precautions for ensuring correct use of the Distributed Multi-channel controller DMC10E, specifications and wiring. Be sure to keep this manual nearby for handy reference.

For further details on correct use, read the Distributed Multi-channel controller DMC10 User's Manual (Description of Functions Version) CP-SP-1057E.

RESTRICTIONS ON USE

This product has been designed, developed and manufactured for general-purpose application in machinery and equipment. Accordingly, when used in applications outlined below, special care should be taken to implement a fail-safe and/or redundant design concept as well as a periodic maintenance program.

- Safety devices for plant worker protection
- Start/stop control devices for transportation and material handling machines
- Aeronautical/aerospace machines
- Control devices for nuclear reactors

Never use this product in applications where human safety may be put at risk.

REQUEST

Make sure that this User's Manual is handed over to the user before the product is used.

Copying or duplicating this User's Manual in part or in whole is forbidden. The information and specifications in this User's Manual are subject to change without notice. Considerable effort has been made to ensure that this User's Manual is free from inaccuracies and omissions. If you should find any inaccuracies or omissions, please contact Yamatake Corporation.

In no event is Yamatake Corporation liable to anyone for any indirect, special or consequential damages as a result of using this product.

SAFETY PRECAUTIONS

Safety precautions are for ensuring safe and correct use of this product, and for preventing injury to the operator and other people or damage to property. You must observe these safety precautions. Also, be sure to read and understand the content of this user's manual.



WARNING

Warnings are indicated when mishandling this product might result in death or serious injury to the user.



CAUTION

Cautions are indicated when mishandling this product might result in minor injury to the user, or only physical damage to this product.



CAUTION

- Before wiring or installing the DMC10S/DMC10D, be sure to turn the power OFF. Failure to do so might cause the DMC10S/DMC10D to malfunction.
- Do not disassemble the DMC10S/DMC10D. Doing so might cause faulty operation.
- Use the DMC10S/DMC10D within the operating ranges (temperature, humidity, vibration, shock, mounting direction, atmosphere, etc.) recommended in the specifications. Failure to do so might cause fire or faulty operation.
- Do not block ventilation holes. Doing so might cause fire or faulty operation.
- Wire the DMC10S/DMC10D properly according to predetermined standards. Also wire the DMC10S/DMC10D using designated power leads according to recognized installation methods. Failure to do so might cause electric shock, fire or faulty operation.
- Do not allow lead clippings, chips or water to enter the DMC10S/DMC10D case. Doing so might cause fire or faulty operation.
- Firmly tighten the terminal screws at the torque listed in the specifications. Insufficient tightening of terminal screws might cause fire.
- Do not use unused terminals on the DMC10S/DMC10D as relay terminals. Doing so might cause electric shock, fire or faulty operation.
- Use Yamatake Corporation's SurgeNon if there is the risk of power surges caused by lightning. Failure to do so might cause fire or faulty operation.
- When disposing of the DMC10S/DMC10D, dispose of it appropriately as industrial waste in accordance with local bylaws and regulations.
- Use the relay on the DMC10S/DMC10D within the rated life described in the specifications. Continued use of the DMC10S/DMC10D outside of the rated life might cause fire or faulty operation.
- The DMC10S/DMC10D will not function for about ten seconds after turning the power ON. Pay attention to this when using the relay output from the DMC10S/DMC10D as an interlock signal.
- Prevent the total power consumption of all linked modules from exceeding 100W. Failure to do so might cause fire or faulty operation.
- Do not supply power from two or more lines to all linked modules. Doing so might cause fire or faulty operation.
- Connect only one DMC10S/DMC10D to all linked modules. Failure to do so might cause the DMC10S/DMC10D to malfunction.
- Connect only one DMC10E to all linked modules. Failure to do so might cause the DMC10E to malfunction.

1. Model Selection Guide

Basic Model No	Number of Channels	Wiring Method	Control Output	Option	Additional Processing	Specifications	
DMC10E	4	C	R	00	00	4-channel output	
						Connector wiring	
							Relay output
							None
							None

2. Names and Functions of Parts

■ Body

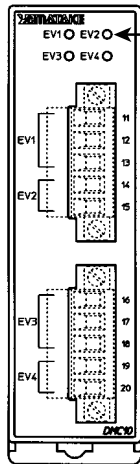

EV1 to EV4 operation lamps:
Light when the relay contact of the target channel inside the module turns ON.

■ Base

Mounting holes (2 locations):
For securing the base with M3 screws

Communications disconnection switch:
Used for disabling local CPL communications with devices linked on the left side (factory setting: CONNECT ←) (linked state)

Mounting hole:
Used for securing on a DIN rail

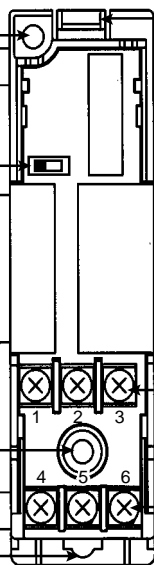

Lever:
For securing the body

Power supply terminal

No.	Signal
1	24Vdc(+)
2	24Vdc(-)
3	Do not use

Local CPL communications terminal:
3-lead RS-485 connector terminal

No.	Signal
4	DA
5	DB
6	SG

- Locations within 15 meters of high-voltage ignition equipment such as boilers
- Locations where magnetic fields are generated
- Locations near flammable liquid or steam

■ Linking modules

The DMC10E can be linked with other modules by the connectors on the left and right of the base. Modules must be linked before the DMC10E is mounted on the DIN rail or mounted by screws.

By linking modules together, the power supply of each module and CPL communications are connected, eliminating the need for wiring.

CPL communications can be disconnected by the communications disconnection switch on the base.

■ Installation Procedure

The DMC10E can be mounted in either of two ways, by mounting its base by screws or by securing on a DIN rail.

● When mounting the base by screws

Secure the two mounting holes on the base by M3 screws.

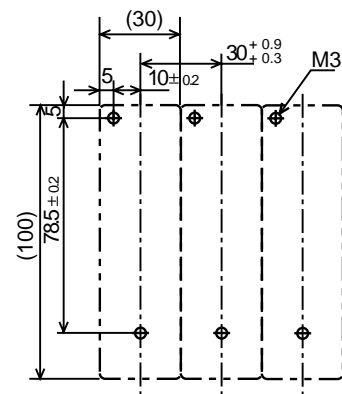

Unit: mm

● When securing on a DIN rail

Secure the DMC10E on the DIN rail, fully draw out the DIN rail stopper and hook the base onto the DIN rail. Next, push the DIN rail stopper upwards until you hear it click into place.

■ Mounting the body on the base

Fit the hook into the base and push the body into the base until you hear it click into place.

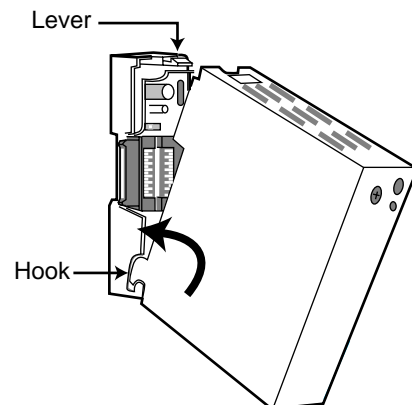

To remove the body from the base, pull the body towards you while pressing down the lever.

3. Installation

■ Mounting Locations

Avoid installing the DMC10E in the following locations:

- Locations subject to low and high temperature and humidity
- Locations subject to corrosive gases such as sulfide gases
- Locations subject to dust or oil smoke
- Locations subject to direct sunlight, wind or rain
- Locations subject to vibration or shock
- Locations under high-voltage lines and near sources of electrical noise such as welders

4. Wiring

■ Wiring Precautions

Be sure to use crimped terminals for wiring terminals. When wiring is finished, check the connections for any miswiring before turning the power ON.

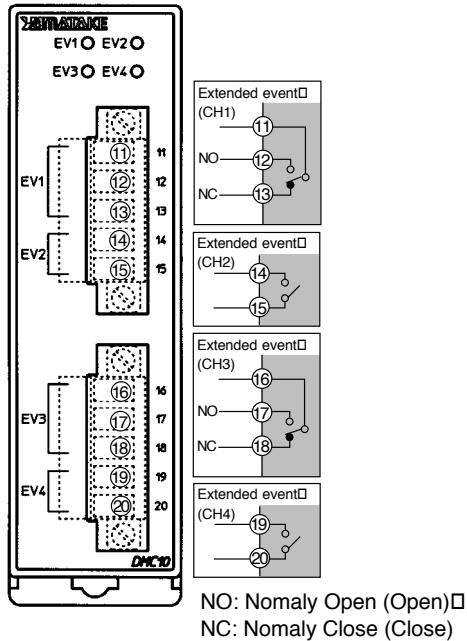

■ Connecting the Power Supply

Connect the power terminal as follows:

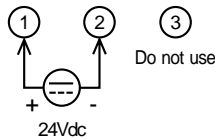

The power supply unit must be a UL approved Class 2 power supply unit or Class 2 transformer in order to apply UL.

! Handling Precautions

- Power is mutually connected between linked modules.
- Supply power to one of the linked modules.
- Select a power supply that can cover the total power consumption of all linked modules.
- Use of free terminal (3) is prohibited. Do not use this terminal, for example, for wiring relays.

■ Connecting CPL communications

CPL communications (RS-485) is performed using a 3-lead connection.

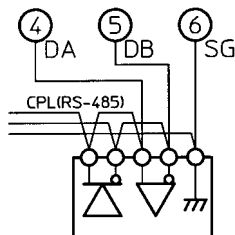

Ex : Connection with a 5-lead device

! Handling Precautions

- Do not connect an external terminator as the DMC10E has a built-in resistor equivalent to a terminator.

- Be sure to connect SG terminals each other. Failure to do so might cause unstable communications.

5. Specifications

■ Specifications

Item	Specifications	
Extended event output	Number of points	4
	Output rating	Output type : Relay contact output Contact type : SPST/2, SPDT/2 Contact rating : 250Vac, 1A 30Vdc, 1A Life : Min. 100,000 operations (resistive load) Min. switching specification: 5V, 10mA
	Type of action	Type of action on DMC10* The type of action can be enabled by setting to bus event output on the DMC10.*
	Optional functions	The same bus event output of each DMC10 is ORed.*
General specifications	Rated power voltage	24Vdc
	Power consumption	Max. 3W (in operating state)
	Insulation resistance	Across primary and secondary sides: Min. 500Vdc 20MΩ
	Dielectric strength	Across primary and secondary sides: 1500Vac 1min
	Power ON rush current	Max. 10A
	Case, base material/color	Polycarbonate/light gray (munsell: 2.5Y7.5/1 or equivalent)
	Operating conditions	Ambient temperature : 0 to 50°C Ambient humidity : 10° to 90%RH Power voltage : 21.6 to 26.4Vdc Vibration resistance : 0 to 2m/s ² (10 to 60Hz, for 2h each in X, Y and Z directions) Impact resistance : 10m/s ² Mounting angle : ±10° of reference plane
	Transport/storage conditions	Ambient temperature : -20 to +70°C Ambient humidity : 10° to 95%RH (condensation not allowed) Vibration resistance : 0 to 5m/s ² (10 to 60Hz, for 2h each in X, Y and Z directions) Impact resistance : 392m/s ² (screw mount) 196m/s ² (DIN rail mount) Package drop test : Drop height 60cm (free fall on one corner, three sides and six surfaces)
	Mass	Max.200g

* For details refer to the Distributed Multi-channel controller DMC10 User's Manual (Description of Functions Version) CP-UM-5143E.

External Dimensions

Unit : mm

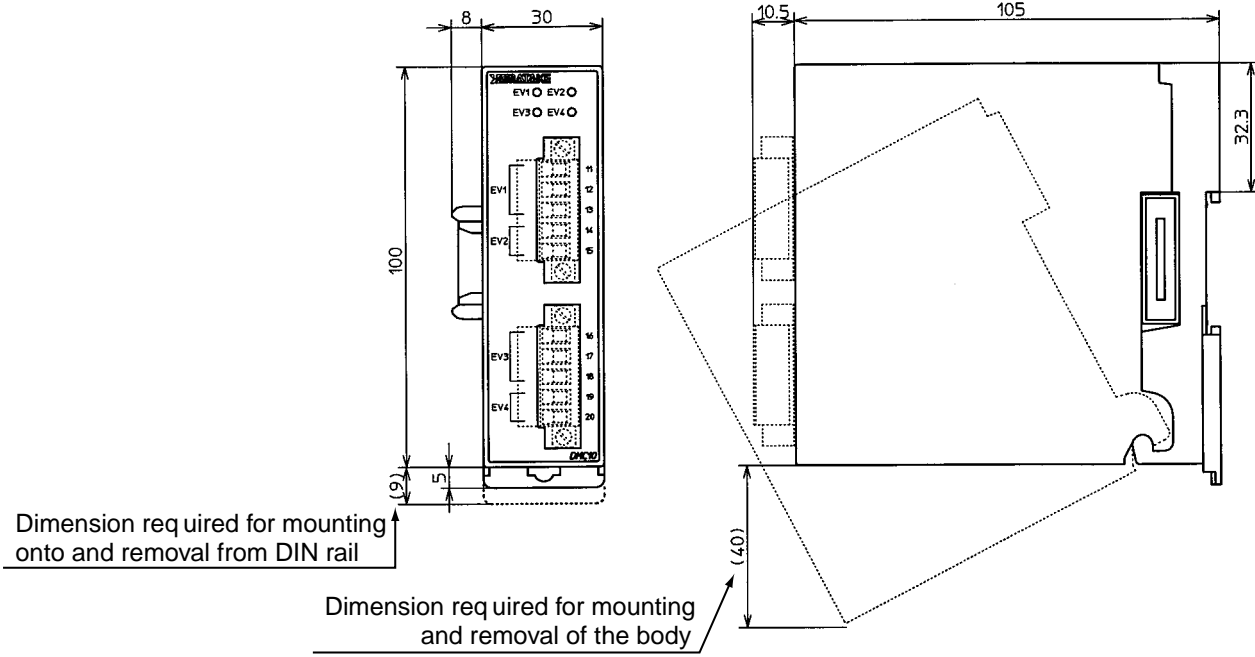

YAMATAKE

Yamatake Corporation
Advanced Automation Company

Totate International Building
2-12-19 Shibuya Shibuya-ku
Tokyo 150-8316 Japan
URL: <http://www.yamatake.com>

This has been printed on recycled paper. (02)

Specifications are subject to change without notice.

Printed in Japan.
1st Edition: Issued in July, 2000(C)
7th Edition: Issued in Apr., 2004(W)