



DigitroniK Digital Indicating Controller SDC30



The SDC30 is a compact (48mm x 96mm) digital indicating controller offering standard PID control, advanced neural/fuzzy PID, multi-range inputs including thermocouple, resistance temperature detector (RTD), DC voltage and DC current inputs.

Remote switch input, control parameters and local set points can be set using the smart handy loader (SHL100).

Specifications

General	Memory backup	Semiconductor non-volatile memory
	Power supply voltage	85 to 265Vac, 50/60Hz, or 24Vdc ± 5%
	Power consumption	18VA max.
	Ambient temperature	0 to 50°C
	Ambient humidity	10 to 90%RH (no condensation allowed)
PV Input	Weight	Approx. 400g
	Type	Multirange: Thermocouple, RTD, DC voltage/current
	Sampling cycle	0.2s
	Bias	-1999 to +9999U (U: industrial unit)
Indication & Setting	PV, SP indication	4-digit, 7-segment LED
	OK lamp	Control deviation value indicated by greenbelt
	No. of setpoints	1 to 8 points selectable
	Range	Selectable
	Indication accuracy	± 0.2%FS ± 1 digit, (not specified for B in 0-260°C range) ± 0.3%FS ± 1 digit for 0-10mV input
	Setting method	Local setting (standard), Remote setting (optional, remote/local changeable)
Control Output	No. of PID sets	8
	PID auto-tuning	Automatic setting of PID value by limit cycle method and neural/fuzzy/smart method
	Output limiter %	Lower: 0 to upper limit Upper: Lower limit to 100
	Control action	Direct/reverse selectable
Remote Switch (RSW) Input	SP ramp	0 to 9999/min, 0 to 999.9/min, 0 to 9999/h, or 0 to 999.9/h
	No. of inputs	1 or 4
	Function	LSP selection (PID group No. interlock), READY/RUN changeover, AUTO/MANUAL, LOCAL/REMOTE, auto-tuning start/stop, direct/reverse and timer start
Event (EV) Output	Type	Dry contact open collector transistor, OFF voltage: 5V±1V ON current: 5mA ± 2mA
	No. of outputs	1 or 2 (common)
Auxiliary (AUX) Output	Type	PV, SP, RSP, RSP before bias, OUT, Motor opening (one type selectable)
	Output	4 to 20mA, load resistance: 750Ω max.
Remote Setpoint (RSP)	Type	4 to 20mA or 1 to 5Vdc
	Bias	-1999 to +9999U
Communications		RS-485
Auxiliary	81446082-001	Hard dust-proof cover
Parts (order separately)	81446086-001	Soft dust-proof cover
	81446088-001	Terminal cover

Selection Guide

I II III IV V Example: C300DA000100

Table	Selection					Description									
I	Basic Model No.	C30	↓	↓	↓	↓	Digital indicating controller								
II	Control output	0D	○	–	○	–	–	Time proportional PID: Relay contact 250Vac, 5A resistive load							
		6D	○	–	○	–	–	Time proportional PID: Voltage 22.5Vdc ± 15%							
		5G	○	–	○	–	–	Continuous proportional PID (4 to 20mA, 570Ω max. resistive load)							
		2G	○	–	○	–	○	Position proportional PID (M/M drive relay contact, 250Vac)							
III	Power supply	A0	○	○	–	–	–	85 to 264Vac, 50/60Hz							
		AZ	○	–	○	○	○	85 to 264Vac, 50/60Hz (with additional RT50 input)							
		D0	○	○	–	–	–	24Vdc ± 5%							
		DZ	○	–	○	○	○	24Vdc ± 5% (with additional RT50 input)							
IV	Option (1)						EV1	EV2	AUX	RSP	RSP	RSW	RSW	RS-	
							4-20mA	1-5V	1 unit	4 units	485				
		001	○	○	–	○	○	–	–	–	–	–	–	–	
		002	–	○	–	–	○	○	–	–	–	○	–	–	
		003	○	–	–	–	○	○	–	–	–	–	○	–	
		004	○	–	–	–	○	○	○	–	–	○	–	–	
		040	–	○	–	–	–	–	–	–	–	–	–	○	
		041	○	–	○	–	○	○	–	–	–	–	–	○	
		402	○	–	○	–	○	○	–	○	–	○	–	–	
		406	○	–	○	–	○	○	○	○	–	–	–	–	
		407	○	–	○	–	○	–	–	○	–	–	–	–	
		502	○	–	○	–	○	○	–	–	○	○	–	–	
		506	○	–	○	–	○	○	○	–	○	–	–	–	
507	○	–	○	–	○	–	–	–	○	–	–	–			
V	Option (2)	00	○	○	○	○	Not available								

Dimensions (unit : mm)

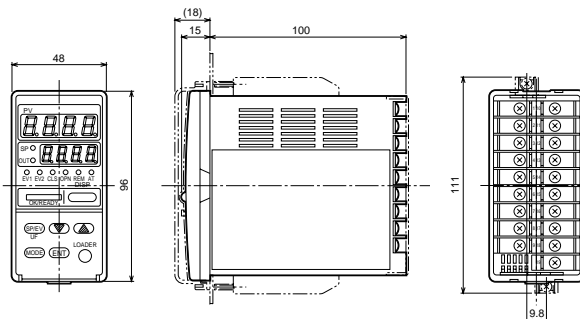

DigitroniK Digital Indicating Controller SDC31



The SDC31 is a compact (48mm x 96mm) digital indicating controller offering standard PID control, advanced neural/fuzzy PID, multi-range inputs including thermocouple, resistance temperature detector (RTD), DC voltage and DC current inputs.

Remote switch input, control parameters and local set points can be set using the smart handy loader (SHL100).

Specifications

General	Memory backup	Semiconductor non-volatile memory
	Power supply voltage	85 to 265Vac, 50/60Hz, or 24Vdc \pm 5%
	Power consumption	18VA max.
	Ambient temperature	0 to 50°C
	Ambient humidity	10 to 90%RH (no condensation allowed)
PV Input	Weight	Approx. 500g
	Type	Multirange: Thermocouple, RTD, DC voltage/current
	Sampling cycle	0.2s
	Bias	-1999 to +9999U (U: industrial unit)
Indication & Setting	PV, SP indication	4-digit, 7-segment LED
	OK lamp	Control deviation value indicated by greenbelt
	No. of setpoints	1 to 8 points selectable
	Range	Selectable
	Indication accuracy	\pm 0.2%FS \pm 1 digit, (not specified for B in 0-260°C range) \pm 0.3%FS \pm 1 digit for 0-10mV input
	Setting method	Local setting (standard), Remote setting (optional, remote/local changeable)
Control Output	No. of PID sets	8
	PID auto-tuning	Automatic setting of PID value by limit cycle method and neural/fuzzy/smart method
	Output limiter %	Lower: 0 to upper limit Upper: Lower limit to 100
	Control action	Direct/reverse selectable
Remote Switch (RSW) Input	SP ramp	0 to 9999/min, 0 to 999.9/min, 0 to 9999/h, or 0 to 999.9/h
	No. of inputs	1 or 4
Event (EV) Output	Function	LSP selection (PID group No. interlock), READY/RUN changeover, AUTO/MANUAL, LOCAL/REMOTE, auto-tuning start/stop, direct/reverse and timer start
	Type	Dry contact open or open collector transistor, OFF voltage: 5V \pm 1V ON current: 5mA \pm 2mA
	No. of outputs	1 or 2 (common)
Auxiliary (AUX) Output	Type	PV, SP, DEV, DEV , MV, Motor feed back, Alarm, Timer, Control loop diagnostics, Estimated motor control mode
	Control mode	ON/OFF SPST relay contact
Remote Setpoint (RSP)	No. of outputs	1
	Type	PV, SP, RSP, RSP before bias, OUT, Motor opening (one type selectable)
Communications	Output	4 to 20mA, load resistance: 750 Ω max.
	Type	4 to 20mA or 1 to 5Vdc
Auxiliary	Bias	-1999 to +9999U
	Type	RS-485
Parts (order separately)	Auxiliary	81446083-001 Hard dust-proof cover
	Parts (order separately)	81446087-001 Soft dust-proof cover
	Parts (order separately)	81446084-001 Terminal cover

Selection Guide

I II III IV V Example: C300DA000100

Table	Selection				Description											
I	Basic Model No.	C31	↓	↓	↓	↓	Digital indicating controller									
II	Control output	0D	○	–	○	–	Time proportional PID: Relay contact 250Vac, 5A resistive load									
		6D	–	○	○	–	Time proportional PID: Voltage 22.5Vdc \pm 15%									
		5G	○	–	○	○	Continuous proportional PID (4 to 20mA, 570 Ω max. resistive load)									
		2G	○	–	○	○	Position proportional PID (M/M drive relay contact, 250Vac)									
III	Power supply	A0	○	○	○	–	85 to 264Vac, 50/60Hz									
		AZ	–	○	○	○	85 to 264Vac, 50/60Hz (with additional RT50 input)									
		D0	○	○	○	–	24Vdc \pm 5%									
		DZ	–	○	○	○	24Vdc \pm 5% (with additional RT50 input)									
IV	Option (1)						EV1	EV2	AUX	RSP	RSP	RSW	RSW	RS-		
							4-20mA	1-5V	1 unit	4 units	485					
		001	○	○	○	○	○	○	–	–	–	–	○	–		
		003	○	○	○	○	○	○	–	–	–	–	○	–		
		005	○	○	○	○	○	○	–	–	–	–	○	–		
		045	○	○	○	○	○	○	–	–	–	–	○	○		
		405	○	–	○	○	○	○	○	–	–	–	○	–		
		446	○	–	○	○	○	○	○	–	–	–	○	–		
505	○	–	○	○	○	○	○	–	○	–	○	–				
546	○	–	○	○	○	○	○	–	○	–	○	–				
V	Option (2)	00	○	○	○	○	Not available									

Dimensions (unit : mm)

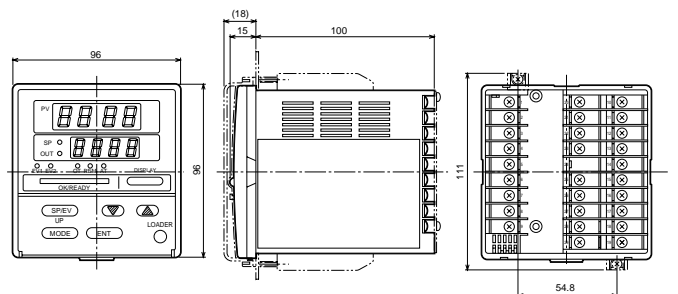

YAMATAKE

Yamatake Corporation
IBD Sensing and Control Department
Totate International Building
2-12-19 Shibuya Shibuya-ku Tokyo 150-8316
Phone:81-3-3486-2311 Fax:81-3-3486-2300

Savemation
Saving through Automation

Printed in Japan, (AB)
Issued 1 Oct., 1998
Rev 2 June, 2000